

Wheelie bin with Rotator Base - 660L

Product Images



Product Dimensions

W660PRB

660L Wheelie Bin with Rotator Base

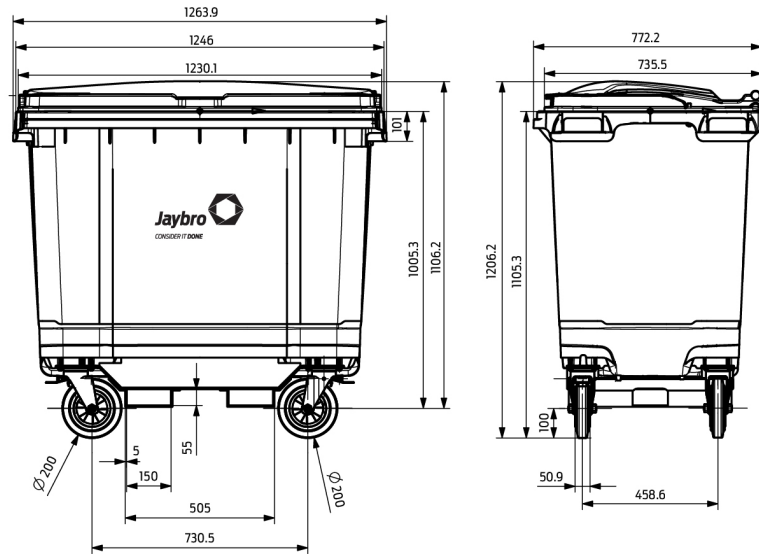

Short Description

Wheelie bin with Rotator Base - 660L

Description

Wheelie bin with Rotator Base - 660L

- Ideal for building site clean up as it fits through standard doorways
- 660 litre wheelie bin suits high volume waste and recycling
- Fork pockets allow emptying by a forklift with rotator attached
- 4 swivel wheels, 2 fitted with brakes for manoeuvrability around the workplace
- 2 large handles on each side
- Resistant to acid, alkali, corrosion and durable to withstand impact
- Zinc finish rotator base / HDPE Bin
- Size: 1370mm(L) x 780mm (D) x 1246mm (H)
- Weight: 72kg
- Colour: Green
- Fork Pocket Size: 160mm x 60mm
- Fork Pocket Centres: 365mm

Additional Information

CODE	64-W660PRB
Weight	250
Colour	Green
Swatch	no_selection

